

Celosia

by Patricia Urquiola

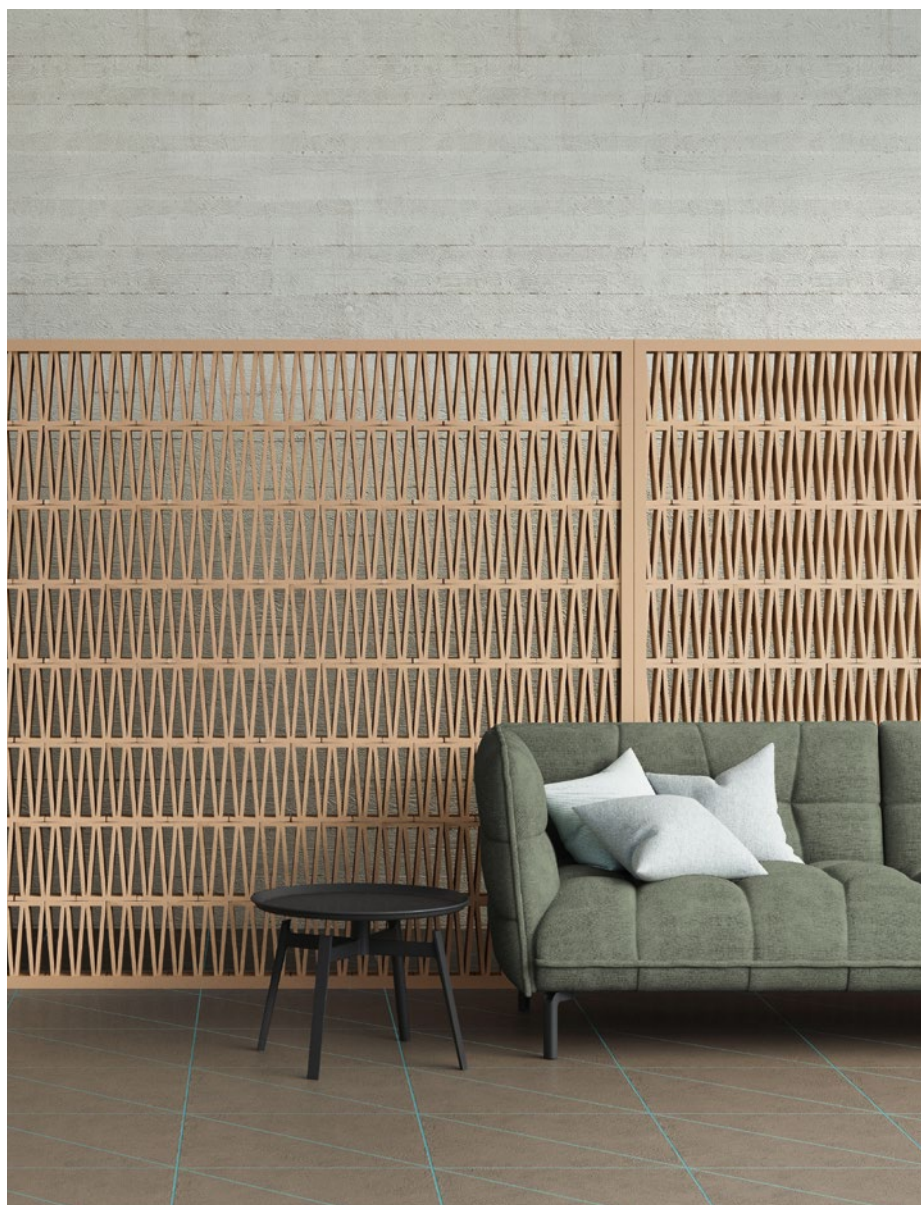

MU
TIN
A

Celosia

by Patricia Urquiola

CREDITS

Art direction: Alla Carta Studio
Graphic design: Matteo Pastorio
Text: Mutina
Images: Germano Schillaci
Backstage images: Matteo Pastorio
Illustration: Damien Florébert Cuypers
Catalogue update: October 2020

All the rights are reserved.
Not any part of this work can be reproduced
in any way without the preventive written
authorization by Mutina. All work is
copyrighted © to their respective owners.

To discover more about Mutina
collections visit mutina.it

Ceramiche Mutina Spa
Via Ghiarola Nuova 16
41042 Fiorano MO, Italia
T +39 0536812800
F +39 0536812808
info@mutina.it
www.mutina.it

© Mutina 2018

Mutina e Patricia Urquiola hanno voluto riproporre tecniche di lavorazione artigianali proprie della terracotta. Elementi che emergono dalla terra, imperfetti e materici, segnati dalla mano dell'uomo e dal passare del tempo. Tegole, mattoni, mattoni forati e gelosie vengono smontati, destrutturati e reinterpretati in una chiave nuova, conservando un'anima tradizionale.

Il desiderio di uscire dalla bidimensionalità propria del rivestimento murario, si traduce nella sperimentazione della tridimensionalità del laterizio, dando forma ad un nuovo elemento di design ad alto contenuto estetico-funzionale con infinite soluzioni applicative per indoor e outdoor.

Celosia per la sua forma, rievoca il sistema di numerazione romano. La sequenza con cui viene posata, crea filtri dinamici e unici.

Mutina and Patricia Urquiola wanted to reprise the traditional artisanal production process typical of terracotta. Elements which come out from earth, imperfect and solid, marked by the hand of man and by time passing. Roof tiles, bricks, hollow bricks and partition walls are undone, unstructured and re-interpreted in a new way, keeping a traditional touch. The wish to exit from two-dimensional spaces typical of standard wall covering, is translated into the experimentation of three-dimensional bricks, which gives shape to new design elements, whose high aesthetic-functional content enables limitless solutions for indoor and outdoor spaces.

Because of its shape, the partition element Celosia evokes the Roman numbering system. The structure followed for its installation creates dynamic and unique partitions.



Avevo bisogno di una materia vera, tattile, che non fingesse di essere altro. Cercavo un elemento caldo, visivamente e al contatto con la mano.

I needed a real tactile material, which did not pretend to be anything else. I was looking for a warm element, both visually and to the touch.

Patricia Urquiola







Sizes & Colors

design	Patricia Urquiola	2018
production	artisanal	
material	terracotta trafilata extruded terracotta	
*	misure nominali/nominal sizes	
size	* 20,5·26,5·10 cm/* 8"·10"·4"	
award	2018 Interior Design's Best of Year	

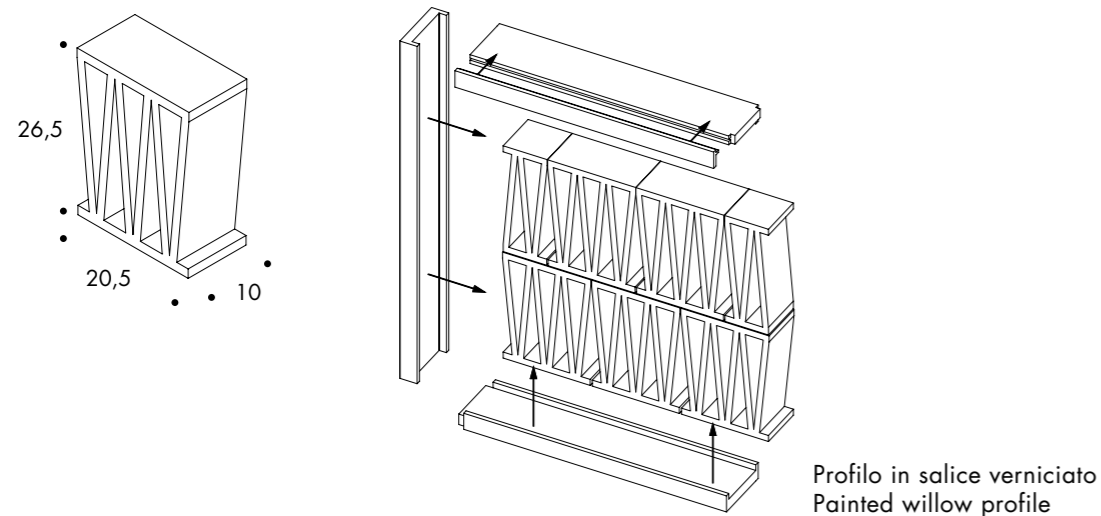

Per facilitare il montaggio di questi elementi è disponibile Mutina sigillante, un sigillante organico eco-compatibile acquistabile separatamente.

To make the installation of these items easier, a Mutina sealant is now available: an organic and eco-friendly sealing material, which is sold separately.

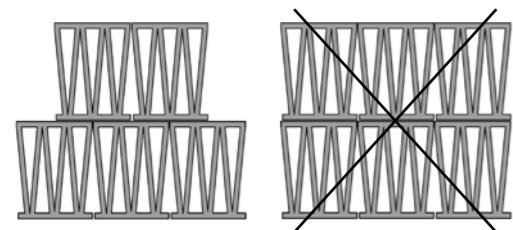

Per ragioni di sicurezza la posa è consentita tassativamente sempre e solo sfalsata.

For security reasons only staggered installation is strictly allowed.

Technical Features

Elementi di produzione artigianale trafilati di spessore 10cm. Gli elementi devono in ogni caso rispettare le norme tecniche in materia di costruzioni vigenti nel paese di utilizzo. Per il territorio nazionale italiano, in particolare, la norma NTC 2018 DECRETO MIN 27/01. Prodotto adatto sia per spazi residenziali che commerciali per la costruzione di pareti di altezza massima 4mt. Per ottenere un risultato estetico ottimale, si consiglia di montare Celosia utilizzando il profilo in legno. Per la chiusura a soffitto è previsto un profilo "terminale" con cornice smontabile. Prodotto adatto per interni ed esterni secondo norma UNI EN 722-22 con marcatura "F1 - esposizione moderata".

Artisanal extruded partition elements, 10cm thick. These elements must in any case comply with the technical standards of construction regulation, applicable in the country where they are installed. For the Italian national territory, in particular, they should comply with standard NTC 2018 DECRETO MIN 27/01.

This product is suitable for both residential and commercial areas, to be installed in walls with a maximum height of 4mt. In order to achieve an optimal aesthetic outcome we advise to install Celosia using our wooden profile. A top profile with removable sides is provided for ceiling fixing. The product is suitable for indoor and outdoor areas complying with UNI EN 722-22 marked "F1 - moderate exposure".

NORMA STANDARD	CARATTERISTICHE FEATURES	VALORE PRESCRITTO VALUE REQUIRED	VALUE
UNI EN 772-16	dimensioni dimensions	da dichiarare to declare	T2 - R2
UNI EN 772-21:2011	assorbimento water absorption	da dichiarare to declare	12.5%
UNI EN 772-5:2016	tenore di sali solubili attivi content of active soluble salts	da dichiarare to declare	S2
UNI EN CEN/TS 772- 22:2006	resistenza al gelo freeze-thaw resistance	da dichiarare to declare	F1
D.M. 1401/2008	determinazione dei carichi variabili orizzontali determination of horizontal variable loads	da dichiarare to declare	C2
LEED CERTIFICATION 4.1			10% recycled material

Packing

FORMATO SIZE	PZ-MQ PCS-SQM	PZ-PAL PCS-PAL	MQ-PAL SQM-PAL	KG-PZ KG-PC	KG-PAL KG-PAL
20,5·26,5·10 cm	18,41	32	1,74	5,50	176

Complementary Pieces

items	<p>Profilo lineare in salice (adatto per uso esterno) Linear painted willow profile (also suitable for outdoor use)</p> <p>Profilo terminale in legno di salice (adatto per uso esterno) con un'estremità sagomata ed un lato rimovibile per facilitare il montaggio della chiusura a soffitto. Top painted willow profile (also suitable for outdoor use) with one shaped end to make clamping easier.</p>
size	* 12,5·300·4 cm/* 4 ^{59/64} "·118 ^{7/64} "·1 ^{37/64} "
*	misure nominali/nominal sizes

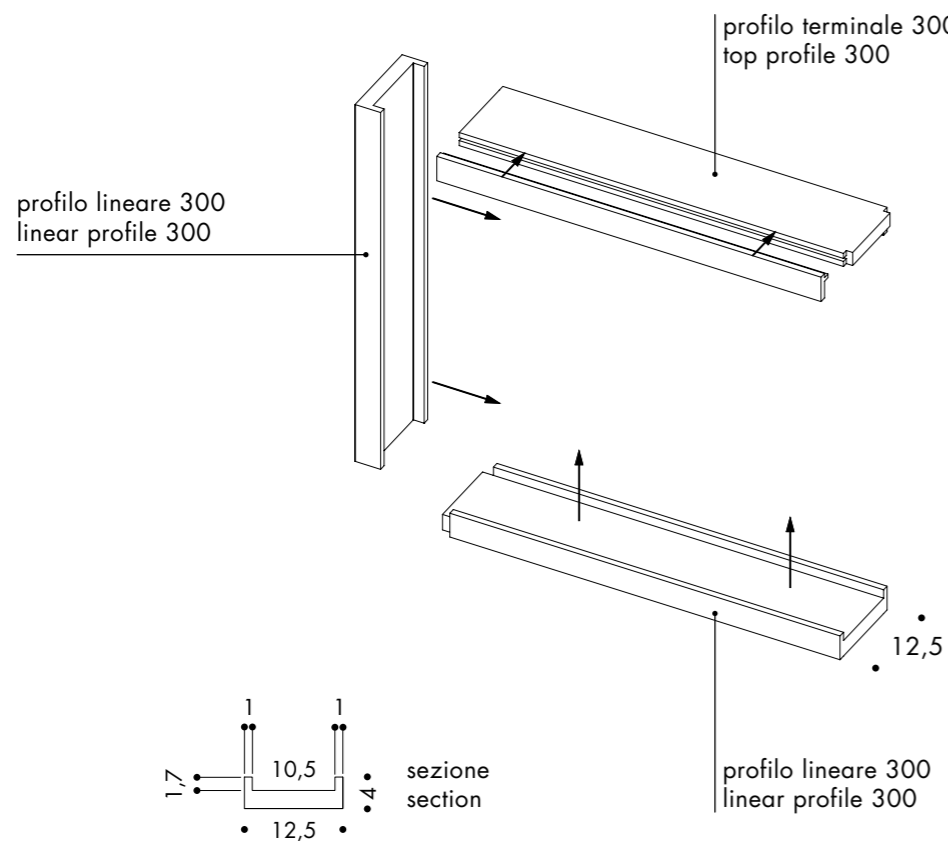

Complementary Pieces

	Mutina sigillante/Mutina sealant
material	<p>Sigillante organico eco-compatibile esente da solventi prodotto da Kerakoll in esclusiva per Mutina Eco-friendly neutral silane sealant with reduced solvent content produced by Kerakoll exclusively for Mutina.</p>
features	<p>Mutina sigillante sviluppa un'elevata adesione su tutti i materiali senza l'utilizzo di primer e un'elasticità permanente su superfici assorbenti e inassorbenti. Mutina sealant develops a high level of adhesion on all materials without the use of primers and permanent elasticity on absorbent and non-absorbent surfaces.</p>
use	<p>In interno, esterno e per sigillature di elementi costruttivi Suitable for indoor and outdoor use, it gives waterproof sealing of construction elements.</p>



Wall Anchoring Scheme

Schema di ancoraggio/ Wall Anchoring Scheme



Fisher SXR fissaggio prolungato 8x80
Fisher long shaft fixing SXR 8x80

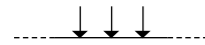

Ancoraggio su 2 lati MAX h400 cm
Anchoring on 2 sides MAX h400 cm

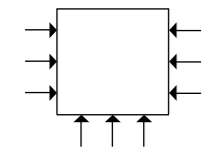

Ancoraggio su 3 lati MAX h400x300 cm
Anchoring on 3 sides MAX h400x300 cm

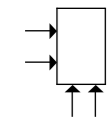

Ancoraggio su 2 lati MAX h250x100 cm
Anchoring on 2 sides MAX h250x100 cm

Patricia Urquiola



Architetto e designer spagnola, ma italiana di adozione, fa parte del team Mutina dal 2008. Ha disegnato numerose collezioni, tra cui: la serie Déchirer, Bas-Relief, Azulej, Tierras e Cover.

Patricia Urquiola è nata a Oviedo, in Spagna, ma vive e lavora a Milano da più di vent'anni. Dopo essersi laureata nel 1989, ha lavorato per Achille Castiglioni, collaborato con Vico Magistretti ed è stata responsabile Design per Lissoni Associati. Nel 2001, ha aperto il suo studio lavorando nei settori del product design, interni e architettura. Ha realizzato progetti retail e allestimenti per Gianvito Rossi, BMW, Flos, Missoni, Moroso, Officine Panerai, H&M, Santoni, Pitti Uomo Firenze e ha vinto diversi premi internazionali tra cui: la "Medalla de Oro al Mérito en las Bellas Artes" del Governo Spagnolo, l'Ordine di Isabella la Cattolica, consegnato da Sua Maestà il Re di Spagna Juan Carlos I, "Designer del decennio" e "Designer dell'anno".

Patricia Urquiola, Spanish architect and director and adopted Italian, is one of the pioneers of the Mutina team. She designed numerous collections since 2008, including the Déchirer series, Bas-Relief, Azulej, Tierras and Cover.

Patricia Urquiola was born in Oviedo, Spain, but has lived and worked in Milan for over 20 years. After her graduation in 1989, she worked for Achille Castiglioni, collaborated with Vico Magistretti and was Head of Design at Lissoni Associati. She opened her own studio in 2001, working in product design, interior design and architecture. She realised retail and fitting projects for Gianvito Rossi, BMW, Flos, Missoni, Moroso, Officine Panerai, H&M, Santoni and Pitti Uomo Firenze and won numerous international prizes including: Medalla de Oro al Mérito en las Bellas Artes and the Order of Isabella the Catholic, awarded to her by King Juan Carlos I of Spain, 'Designer of the Decade' and 'Designer of the Year'.